

Vargfors Dam Fibre installed in the toe of the dam during toe berm construction

The embankment dam at Vargfors is about 700m long and is parallel to the river Skellefteälven.

In 2001, a support toe berm was constructed as well as new drainage ditch. In connection to this work an optical fibre cable was installed at the dam toe (see fig 5). The fibre optic cable is placed in the bottom of the ditch, just upstream of the two drainage pipes in order to allow temperature measurements of the water that seeps through the dam and out into the drainage ditch.

The objective with the fibre installation is to detect seepage areas with DTS, as a complement to conventional seepage monitoring in weirs.

Drainage pipes parallel to the dam toe are connected regularly to wells (called TB1- TB19), where the directional changes are made, and/or additional drainage pipes are added. These additional drainage pipes are directed more or less upstream into the dam in order to reduce the pressure in the downstream part of the dam. At such situations the fibre follows the upstream ditch upstream and downstream before continuing along the dam toe.

The first measurement was performed in 9-10 December 2003 in order to check the status of the installation and obtain initial temperature data. The

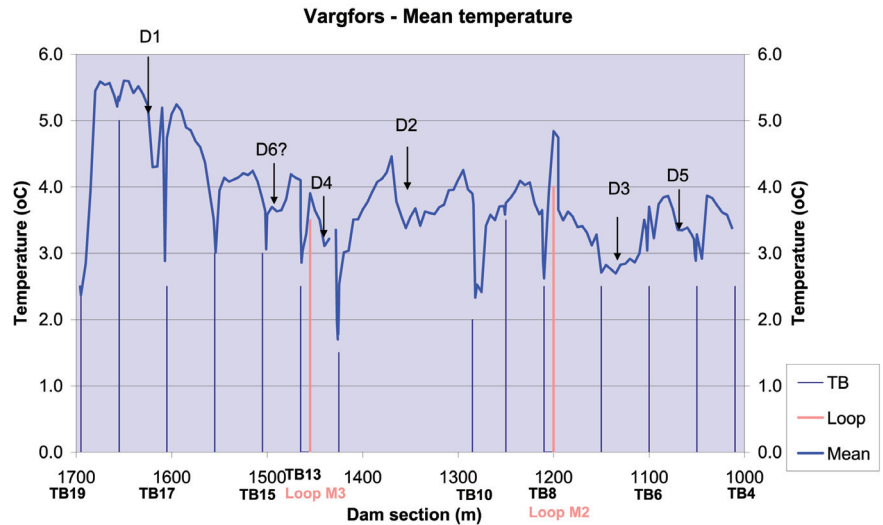

Figure 6 | Temperature on each 5m along the dam section

temperature is given for each meter along the dam, but in the diagram below the result has been transformed to approximately correspond to the dam chainage.

The result shows generally normal seepage conditions with a few possible seepage concentrations. The dip (D1) at section 1/615-1/620, is distinct and exhibits about 1°C lower temperature than adjacent parts (see figure 6). This might be a sign of some higher seepage than in the other parts of the dam. The general temperature in the dam (between 3-4°C) indicates normal seepage conditions.

The temperature dips that coincide with the TBs are not caused by seepage. The reason is that the upstream drain gives a shorter travel length for the seepage water, compared to its travel length to the dam toe. Therefore, a faster temperature response of the decreasing temperature in the river is seen.

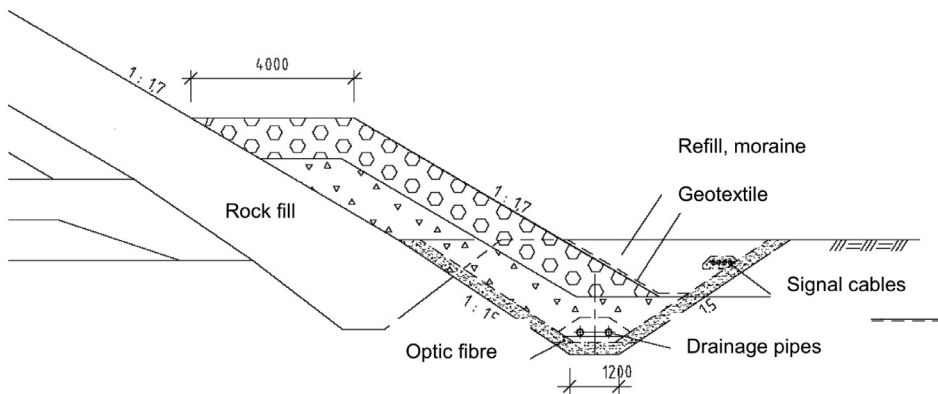

Figure 5 | Cross section of the installation at Vargfors

HydroResearch | Stora Askens väg 6 | S-183 65 | Täby | Sweden
Tel +46 8 756 4950 | Email sam.johansson@hydroresearch.se

www.hydroresearch.se

Sensornet Limited | 198 Providence Square | Jacob Street | London | SE1 2DZ | United Kingdom
Tel +44 (0)20 7394 3555 | Fax +44 (0)20 7394 0555 | Email enquiries@sensornet.co.uk

www.sensornet.co.uk

